

Inductive Displacement Transducer

Series **SM32**



- Stroke up to 15mm
- Integral electronic circuit
- Protection class IP66
- Accuracy 0,5% or 0,25%

Construction and operating principle:

A nickel iron core will be moved linear inside of a coil form. The displacement of the core leads to a inductance variation in both coils. The integral electronic circuit convertes the variation into a signal proportional to the displacement.

Standard measuring stroke:

5 mm	10 mm	15 mm
------	-------	-------

Technical data:

Accuracy	< 0,5% or 0,25%
Temperature drift	< 0,01% / °C
Measurment frequency	800 Hz
Temperature range	-20°C to +85°C
Resistance to shock	250g SRS 20-2000Hz
Resistance to vibration	20g rms (50g peak)
Protection class	up to IP66*

* with mounted mating plug B1423

Note: Unless otherwise stated, all values are valid at +20°C ambient temperature and 30 VDC or ±15 VDC supply voltage, starting 10 minutes after switch-on.

Standard versions:

Type	output	Supply voltage U_B *	signal**	mid
SM321	0 .. 20 mA	20 .. 32 V	increasing	10 mA
SM322			decreasing	
SM323	4 .. 20 mA	20 .. 32 V	increasing	12 mA
SM324			decreasing	
SM325	± 10 V	±13 .. ±16 V	increasing	0 V
SM326			decreasing	
SM327	0..10 V	20 .. 32 V	increasing	5 V
SM328			decreasing	

* Pole reversal protection

** Increasing signal by moving the plunger in the direction towards the plug

Dimensions in mm:

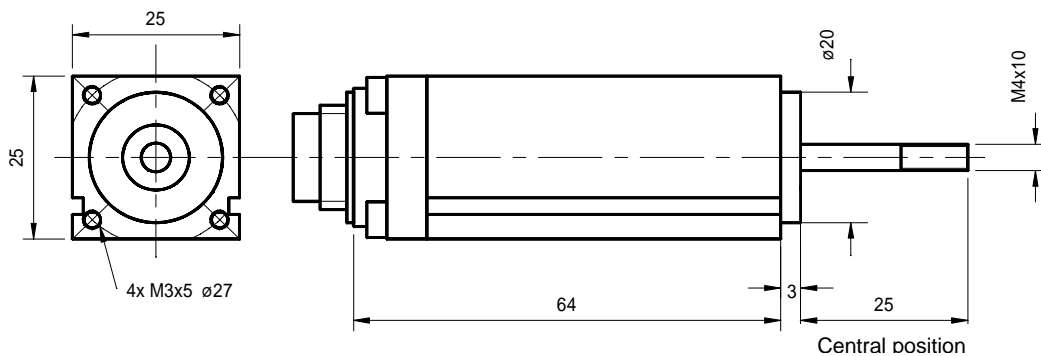

Gauge with bellow, plug (.BS)

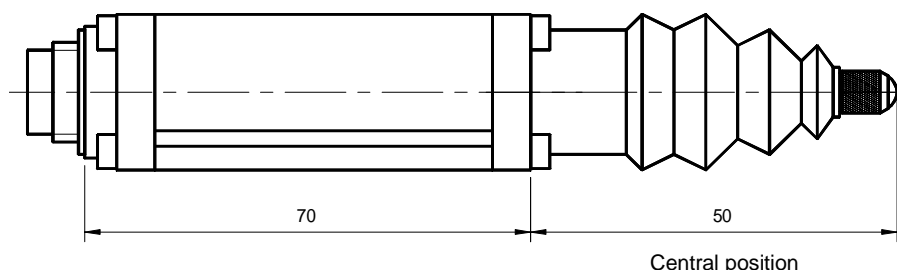

Front plate (.L)
Aluminium 3mm
black anodized

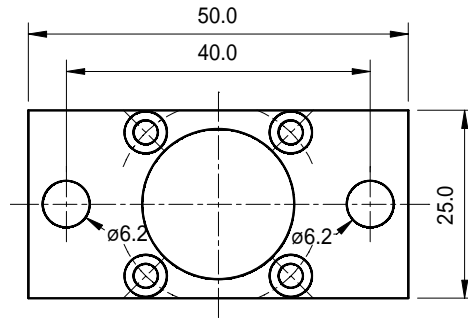

ball joint with guided and captivated plunger, ball joint on end of case, cable exit (.FGHK1)

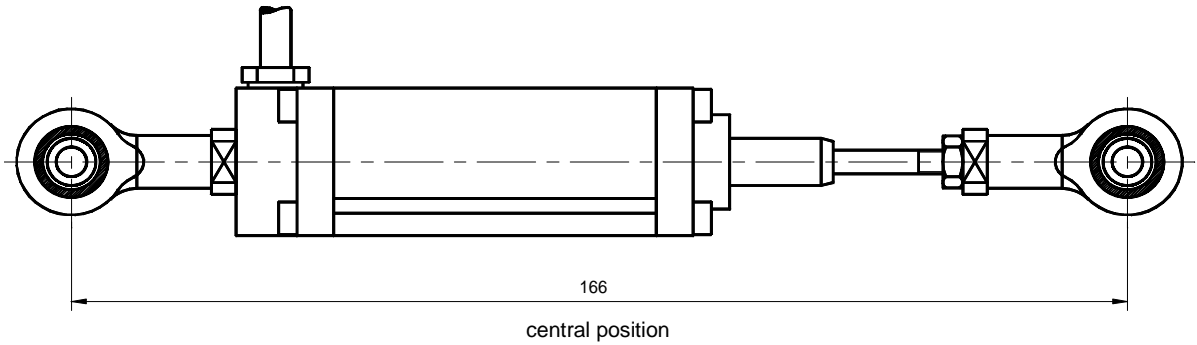

gauge without bellow, plug (.ST)

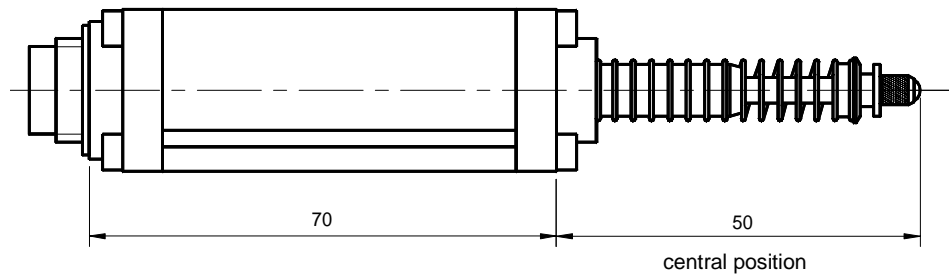

gauge without bellow, mounting thread M16x1,5, plug (.MST)

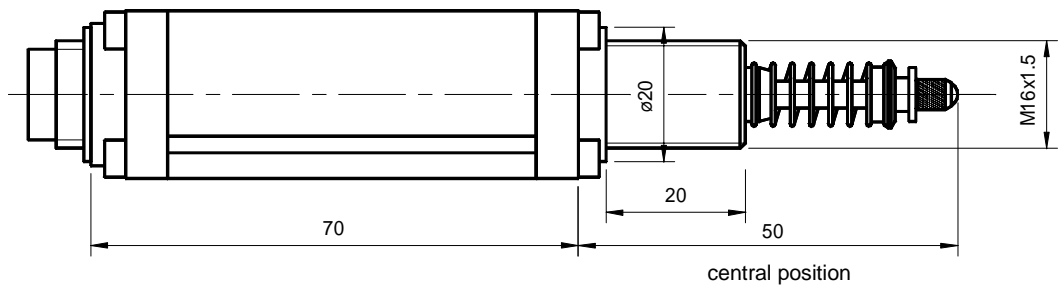

mounting thread M16x1,5, cable exit, cable length 1m (.K1M)

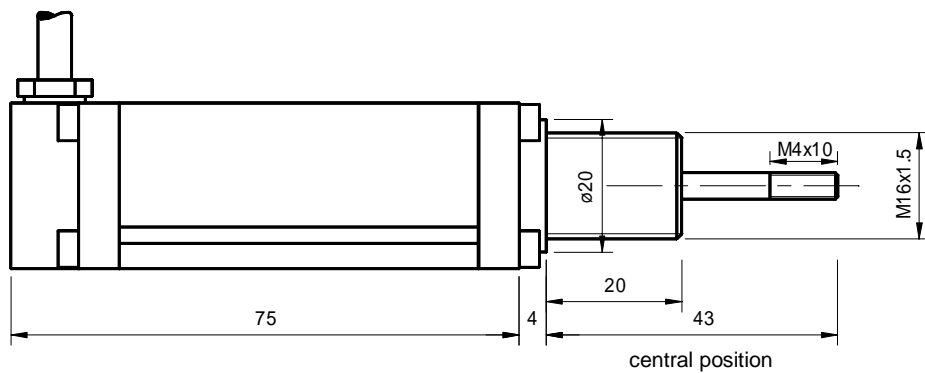

Current output (SM321..324):

Output signal	0..20 mA or 4..20 mA
Supply current I _B	max. 60 mA
Load resistance R _L	0..500Ω
Residual ripple	< 0,005 mA _{SS}
Dependence on R _L	< 0,001% for ΔR _L = 100Ω
Dependence on Vs	< 0,05% for ΔU _B = 1V

Voltage output (SM325..328):

Output signal	±10 VDC
Supply current I _B	max. 50 mA
Permissible load R _L	≥ 2 kΩ (short-circuit proof)
Residual ripple	< 5 mV _{SS}
Residual voltage SM327/328	max. 0,1VDC
Dependence on Vs	< 0,05% for ΔU _B = 1V

Materials:

housing	anodized aluminium
plunger	stainless steel
core	stainless nickel iron alloy
Connector case	nickel plated brass
Connector contacts	gold plated brass

Electrical connections on plug

(view to the plug at transducer)

3-channel output 1, 2, 3, 4, 7, 8	4-channel output 5, 6
Cable colour 1: +U _B red 2: -U _B (0V) black 3: I _A / U _A (output) brown	Cable colour 1: +U _B red 2: 0V orange 3: -U _B black 4: U _A (output) brown

Option and accessories:

version .B	with bellow
version .K	cable exit
version .M	mounting thread M16x1,5
version .T	gauge
SM906.320	mounting clamps

Mating plugs:

(must be orderd separately)

IP40: Binder Ser. 681 3PS/4PS
Metal case

IP66: Binder Ser. 423M 3PS/4PS

Order code

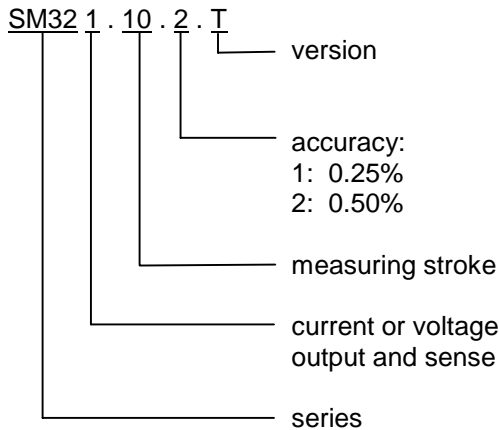

Order codes for customer specified versions will be named at plant.

mounting clamps
SM906.320

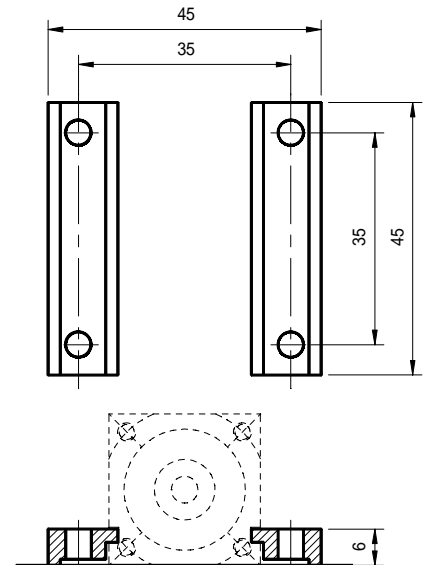

Incl. 4 screws M4x12 DIN 912

Your Distributor

FTMESURES

