

HANDYSENS^W

HANDHELD SIGNAL CONDITIONER FOR (WLPI) TECHNOLOGY



KEY FEATURES

- Compact and rugged design
- Portable battery operated unit
- Sampling rate up to 250 Hz
- Large convenient touchscreen display
- Ethernet & USB interface
- Support strain, pressure, temperature and position sensors

HANDYSENS^W OPSENS SOLUTIONS' (WLPI) TECHNOLOGY

DESCRIPTION

The HandySens^W is a **compact and portable** signal conditioner to be used with any of Opsens Solutions' interferometric fiber optic sensors, i.e. the WLPI fiber optic sensors, for temperature, pressure, strain, and position measurements.

At the heart of the HandySens^W is the Opsens Solutions' White Light Polarization Interferometry (WLPI) technology (patent # 7,259,862) which provides a mean for making accurate and absolute measurements of the path length difference of any type of interferometric fiber optic sensors, whose difference varies according to the measure and of interest.

The HandySens^W unit is the latest generation of Opsens Solutions' signal conditioners equipped with state-of-the-art technologies. Highly versatile, it supports a broad range of fiber optic sensors and offers measurement **sampling rate up to 250 Hz**.

The HandySens^W is equipped with a large and practical 5.0" touchscreen display and can be battery operated for remote monitoring projects. The single channel signal conditioner can be controlled directly using the touchscreen display or remotely using Ethernet Interface 10/100 Base-T and/or USB for real-time data acquisition. The unit is equipped with internal storage to provide the required autonomy in remote locations.

APPLICATIONS

- Geotechnical applications
- Civil Engineering: monitoring infrastructures
- Industrial: automation and process control
- Portable or benchtop controller
- High voltage conditions
- EMI, RFI and microwave environments
- Hazardous and nuclear environments
- Autonomous monitoring in remote areas



HANDYSENS^W

HANDHELD SIGNAL CONDITIONER FOR (WLPI) TECHNOLOGY

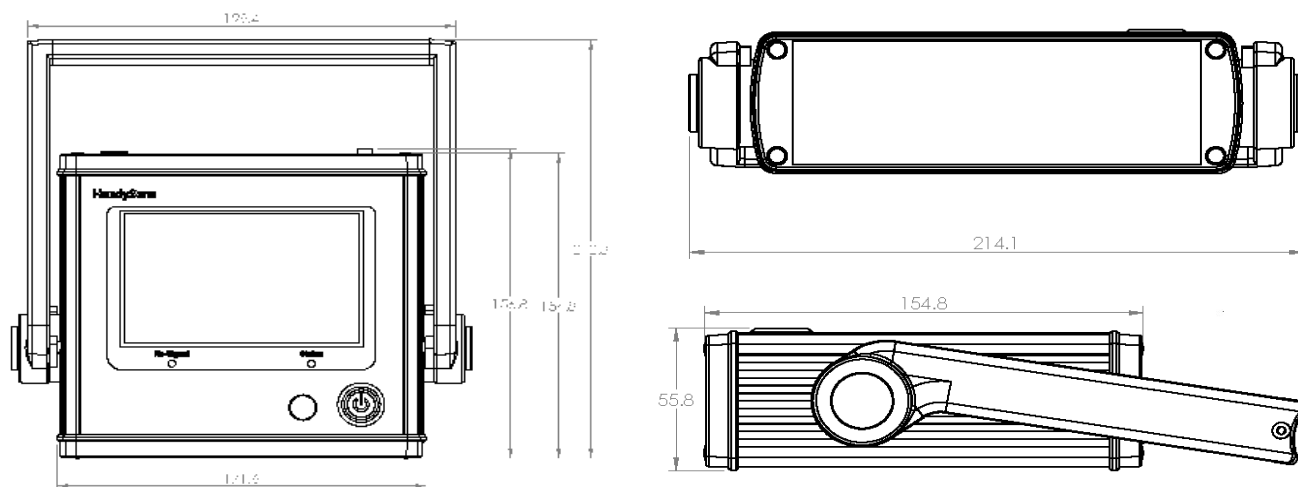

All units are in millimeters

SPECIFICATIONS

NUMBER OF CHANNELS	Single
DISPLAY	5.0" color (800x480) capacitive touchscreen.
SAMPLING RATE	User defined 2Hz to 250 Hz.
ANALOG OUTPUTS	0-5 V, ± 5 V, 0-10 V, 0-20mA, 4-20 mA
COMMUNICATION INTERFACES	Ethernet Interface 10/100 Base-T and USB
INPUT VOLTAGE AND FREQUENCY	24V to 32 V (AC/DC wall-transformer adapter included)
CONSUMPTION	Max power 36W (during battery charging)
BATTERY	Rechargeable battery with an autonomy of 8 hours
DIMENSION & WEIGHT	55.8 mm (H) x 199.4 mm (W) x 214.1 mm (L) - 0.68 Kg
STORAGE TEMPERATURE	-40 °C to 70 °C
OPERATING TEMPERATURE	0 °C to 50 °C
HUMIDITY	95 % non condensing
INTERNAL STORAGE	32 Gigabytes
COMPATIBILITY	All Opsens Solutions' WLPI fiber optic sensors