

FIBER OPTIC PRESSURE SENSOR

SPOT-WELDABLE FIBER OPTIC PRESSURE SENSOR



KEY FEATURES

- Small and low weight spot-weldable
- Low and smooth profile design
- Rugged stainless steel body
- Complete EMI/RFI/Lightning immunity
- Intrinsically safe
- Field-proven accuracy and long term reliability
- Signal conditioner can be mounted on rotating parts

OPP-GF Low and smooth profile

DESCRIPTION

Opsens Solutions' OPP-GF, MEMS-based fiber optic pressure sensor specially packaged for spot welding installation. Its low and smooth profile is perfectly tailored to meet the challenges of pressure monitoring applications in environments where fluid flow and aerodynamic forces must not be perturbed by the presence of the sensor.

The OPP-GF sensor delivers long term accuracy and durability with a pressure operating range of up to 700 kPa. It is particularly well adapted for pressure monitoring of blade turbine surfaces, wind and hydraulic tunnels and penstock pipes. Mounted into a rugged stainless steel body, the OPP-GF is designed to work in hazardous and corrosive environments.

The OPP-GF pressure sensor is compatible with all Opsens Solutions' WLPI (Patent #7,259,862) signal conditioners. The sensor can be mounted with a fiber optic cable of a length of up to three kilometers. This permits to locate its signal conditioner far away from the measuring zone. The later can be mounted on rotating parts as well such as the hub of a turbine shaft.

APPLICATIONS

- Blade turbine surface pressure monitoring
- Penstock pipe pressure monitoring
- Energy applications
- Aerospace and Defense
- Wind and hydraulic tunnels pressure monitoring
- Geotechnical applications
- Hazardous, corrosive and nuclear environments
- Small and confined space application

OPP-GF

SPOT-WELDABLE FIBER OPTIC PRESSURE SENSOR

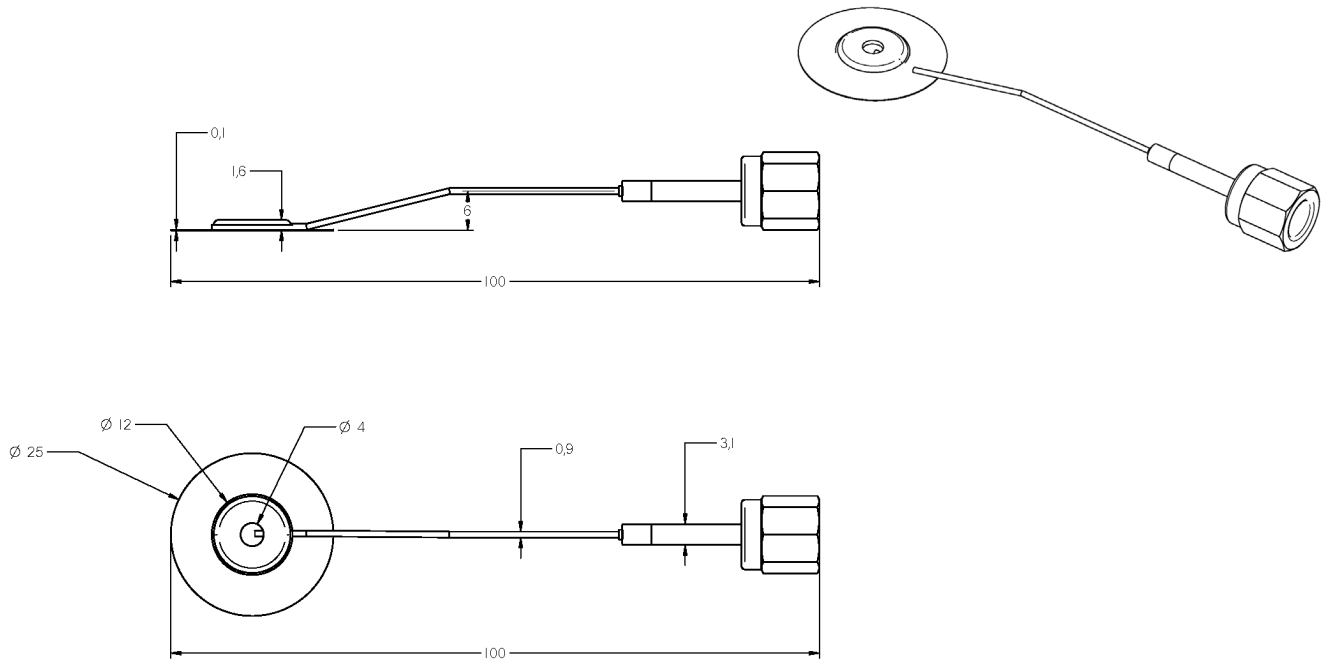

SPECIFICATIONS

MEASURING RANGE (other ranges available on request)	25 PSI (172 kPa)	50 PSI (345 kPa)
RESOLUTION	< 0.02 % F.S. (Range dependant)	
PRECISION	±0.5 % F.S. (Excluding thermal effect)	±0.2 % F.S. (Excluding thermal effect)
THERMAL COEFFICIENT OF ZERO	< 0.03 % F.S. / °C	
PROOF PRESSURE	200 % F.S.	
TEMPERATURE OPERATING RANGE	-45°C to 65°C	
EMI/RFI LIGHTNING	Complete immunity	
HOUSING	Stainless steel	
WEIGHT	10 grams	
CABLE LENGTH	Up to 3 km (Sampling rate dependent, consult factory for more details)	
OPTICAL CONNECTOR	SCA (Standard), SC (Standard), other connector available on request	
CABLE SHEATHING	From ruggedized flexible outdoor cable to robust stainless steel cable	
SIGNAL CONDITIONER COMPATIBILITY	All Opsens Solutions' WLPI signal conditioners	