

FIBER OPTIC EXTENSOMETER SENSOR

FOR CONCRETE EMBEDMENT

KEY FEATURES

- Maintenance free without drifting over time
- Outstanding repeatability
- Insensitive to transverse strains
- Intrinsically safe
- No Temperature compensation required



OEP-C Robust - Reliable

DESCRIPTION

Based on Opsens Solutions' unique WLPI signal conditioning technology (Patent # 7,259,862) and the inherent advantages of fiber optics strain sensor, the robust extensometer is designed to provide a **100% survivability**. Not affected by **transverse strain** and without drifting over time, the concrete embeddable extensometer is perfectly tailored for permanent monitoring of infrastructure, provide continuous reliable measurements in almost any conditions.

The fast response sensor can be used in both dynamic and static surveillance applications. It will not be affected by the surrounding environment like other sensing technologies. For instance, **no need to compensate for temperature variation**.

The robust stainless steel design can be fixed inside the formwork or cast directly into the wet mix. A **string of extensometers** integrated into a single cable is also available. This enable strain monitoring on multiple location of a structure, without complex cable management.

Different cables and sheath options are available, to meet customer specific requirements.

APPLICATIONS

- Pile testing
- Dam and tunnel surveillance
- Structural integrity of bridge and viaduct
- Road pavement instrumentation
- Foundation monitoring in High Voltage environments
- Concrete structure in Nuclear and hazardous environments

OEP-C

FIBER OPTIC EXTENSOMETER SENSOR FOR CONCRETE EMBEDMENT

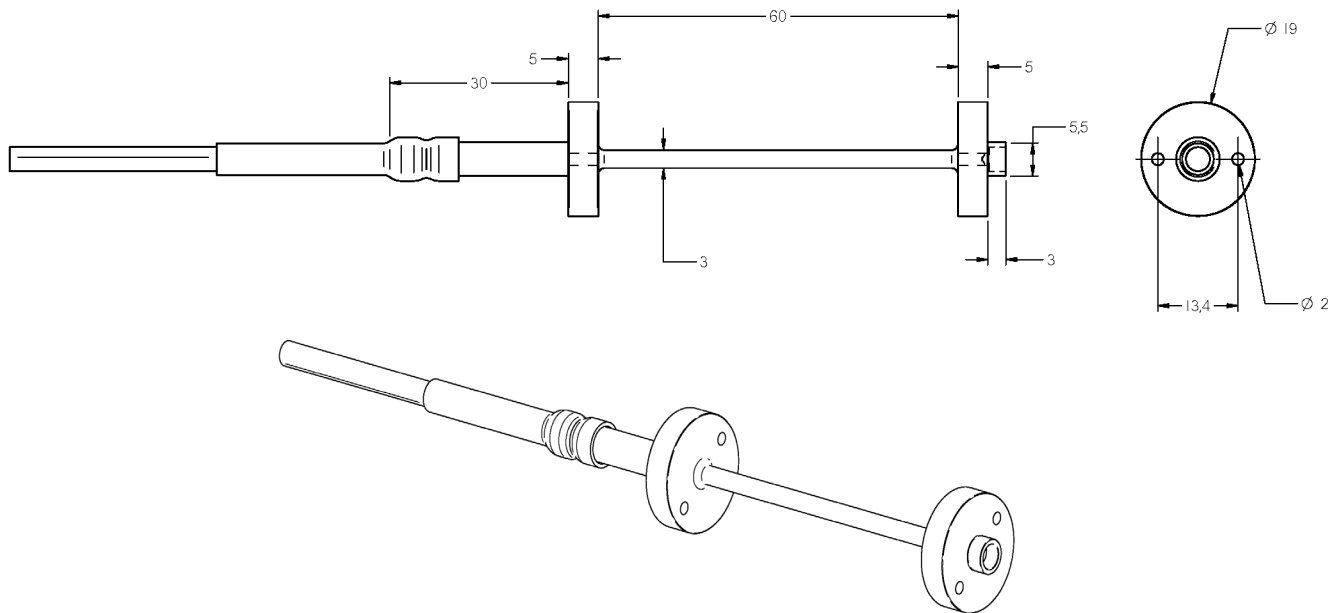

SPECIFICATIONS

MEASURING RANGE (other ranges available on request)	-1 000 to +1 000 $\mu\epsilon$	-2 500 to +2 500 $\mu\epsilon$
RESOLUTION	0.15 $\mu\epsilon$	
TEMPERATURE SENSITIVITY	Insensitive	
TRANSVERSE STRAIN SENSITIVITY	Insensitive	
TEMPERATURE OPERATING RANGE	-40°C to +60°C (other temperatures available on special request)	
EMI/RFI SUSCEPTIBILITY	Complete immunity	
CABLE LENGTH	Up to 3 km (Sampling rate dependent, consult factory for more details)	
OPTICAL CONNECTOR	LCA or SCA (Standard), other connector available on request	
CABLE SHEATHING	From ruggedized flexible outdoor cable to robust stainless steel cable	
SIGNAL CONDITIONER COMPATIBILITY	All Opsens Solutions' WLPI signal conditioners	
EXTERNAL CASING	Stainless Steel 316L	
LINEARITY, REPEATABILITY and HYSTERESIS ERROR (combined)	< 0.15%	