

5100-5105

## CAPTEURS DE FORCE EN TRACTION ET COMPRESSION (TRES HAUTES CAPACITES)

Capteurs de force universels associant précision et simplicité de mise en œuvre.



Modèle 5105



### Caractéristiques

- o Large gamme de capacités : de 10 kN (1 t) à 50 MN (5.000 t)
- o Faible encombrement, structure compacte
- o Classe de protection : IP66
- o Matière : acier inoxydable (5100)\*\* ou acier nickelé (5105)
- o Longueur du câble : voir dessin - CL (autres longueurs disponibles sur demande)
- o Existe aussi en version capteur étalon suivant ISO 376 (classes 1, 0,5 and 00 voir la documentation spécifique - fiche produit 5105-ISO)

### Options les plus fréquentes



Double pont de Wheatstone



Sortie amplifiée



Sortie digitale



Sans fil



Ex i



-50°C...+180°C

**Application(s)** Les modèles 5100-5105 de FT Mesures sont parfaitement conçus pour répondre aux applications suivantes :

- Mesure de force industrielle et mesure sur bancs de test,
- Pesage suspendu.

### Capacités

5100 - 5105 : (10) - (15) - 20 - 30 - 50 - (75) - 100 - (150) - 200 - 300 - 500 kN  
(0.75) - 1 - 1.5 - 2 - 3 - 5 - 7.5 - 10 - 15 - 20 - 30 - 40 - 50 MN

Spécifications	0.25 %	0.1 %	0.05 %	0.03 %	
Classe de précision	0.25 % P.E.*	0.1 % P.E.*	0.05 % P.E.*	0.03 % P.E.*	-
Erreur combinée (non-linéarité + hystérésis)	<± 0.25	<± 0.1	<± 0.05	<± 0.03	% P.E.*
Erreur de répétabilité	<± 0.1	<± 0.03	<± 0.02	<± 0.015	% P.E.*
Fluage sur 30 min.	<± 0.1	<± 0.06	<± 0.04	<± 0.025	% P.E.*
Retour à zéro	<± 0.025	<± 0.015	<± 0.01	<± 0.0075	% P.E.*
Température de référence	23	23	23	23	°C
Température compensée	-10...+45	-10...+45	-10...+45	-10...+45	°C
Température opérationnelle	-25...+70	-25...+70	-25...+70	-25...+70	°C
Température de stockage	-50...+85	-50...+85	-50...+85	-50...+85	°C
Dérive thermique de sensibilité	<± 0.05	<± 0.05	<± 0.035	<± 0.015	% P.E./10°C
Dérive thermique du zéro	<± 0.035	<± 0.035	<± 0.03	<± 0.023	% P.E./10°C
Plage du zéro initial	± 0.02	± 0.02	± 0.02	± 0.02	mV/V
Sensibilité nominale	1...2	1...2	1...2	1...2	mV/V
Tolérance de sensibilité	<± 0.3	<± 0.3	<± 0.3	<± 0.2	%
Résistance d'entrée	350...700 ± 2	350...700 ± 2	350...700 ± 2	350...700 ± 2	ohm(s)
Résistance de sortie	350...700 ± 2	350...700 ± 2	350...700 ± 2	350...700 ± 2	ohm(s)
Résistance d'isolement (50 V)	> 5000	> 5000	> 5000	> 5000	Mohm(s)
Tension d'alimentation de référence	10	10	10	10	VDC
Tension d'alimentation nominale permise	3...12	3...12	3...12	3...12	VDC
Charge maximale admissible	150	150	150	150	% P.E.*
Charge de rupture	>300	>300	>300	>300	% P.E.*

\* P.E. : Pleine Echelle.

\*\* les options CSA et IECEx sont disponibles uniquement pour le modèle en inox - 5100

Les spécifications peuvent être modifiées sans avertissement.

5100-5105 > DIMENSIONS STANDARD

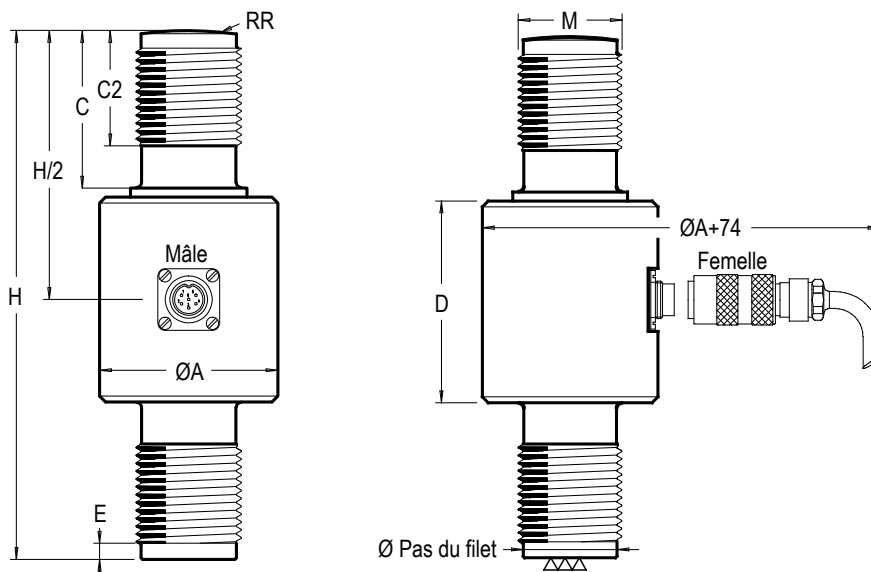

Ref. Item*	Capacités	Ø A	C	C2	D	E	H	RR	CL (m)	M	H1	H2	Déformation à pleine échelle	Poids (kg)	ACCESSOIRES		
															EMBOF	PADIN	SUPOR
510x-A	10 - 50 kN	50	36	26	47	3	125	75	3	M24x2	245	307	0.02 - 0.08	0.8	EMBOF-M24x2-BA	PADIN-24**	SUPOR-24
510x-B	75 - 100 kN	60	48	35	73	3	170	80	3	M30x2	320	402	0.13 - 0.15	1.9	EMBOF-M30x2-BA	PADIN-30	SUPOR-30
510x-C	150 - 200 kN	75	49	44	87	4	190	350	6	M45x3	398	510	0.14 - 0.16	3.65	EMBOF-45x3-PTFE	PADIN-45	SUPOR-45
510x-D	300 - 500 kN	88.5	69	59	119	5	265	400	6	M64x4	560	740	0.19 - 0.25	9.8	EMBOF-64x4-PTFE	PADIN-64	SUPOR-64
510x-E	0.75 - 1.5 MN	111	95	80	145	5	340	400	6	M90x4	/	/	0.30 - 0.42	21	/	PADIN-100A	SUPOR-90
510x-G	2 MN	150	128	120	165	7	430	600	6	M125x4	/	/	0.35 - 0.65	38	/	PADIN-125A	SUPOR-125A
	3 MN																
510x-H	5 MN	180	162	158	180	8	520	800	6	M160x6	/	/	0.73	87	/	PADIN-160	SUPOR-160
510x-I	7.5 MN	220	205	175	200	10	590	1000	6	M200x6	/	/	0.83	151	/	PADIN-200A	SUPOR-200A
	10 MN																
510x-K	15 MN	280	250	230	230	10	710	1200	12	M250x6	/	/	1	292	/	PADIN-250	SUPOR-250A
510x-L	20 MN	360	380	340	320	36x30°	1080	1500	12	TR 330x24	/	/	1.7	700	/	PADIN-330A	SUPOR-330A
510x-M	30 MN	450	460	420	540	36x30°	1460	2000	12	TR 400x24	/	/	2.26	1420	/	PADIN-400A	SUPOR-400A
-	40 - 50 MN	Selon les spécifications de conception du client															

\*x=Matière : 5100 - acier inoxydable ; 5105 - acier nickelé

\*\* PADIN-24 uniquement pour 50 kN; PADIN non nécessaire pour les capteurs < 50 kN

→ Autres capacités et dimensions disponibles sur demande

Dimensions en mm

Accessoires



Schéma de câblage



Standard : Faradisation non connectée au capteur

Direction de la force

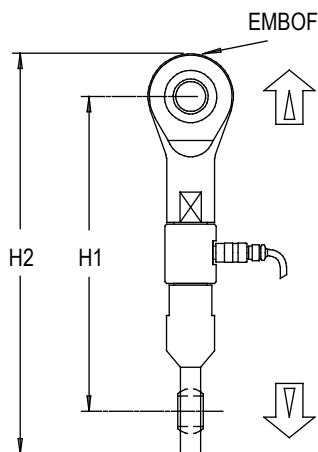
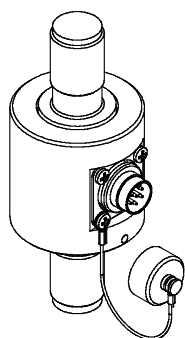
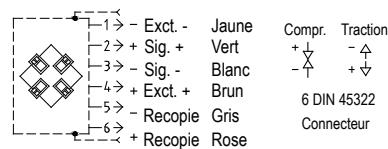
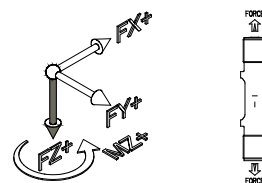

EMBOF > DIMENSIONS STANDARD

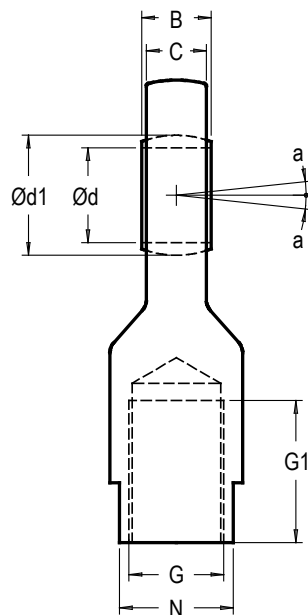
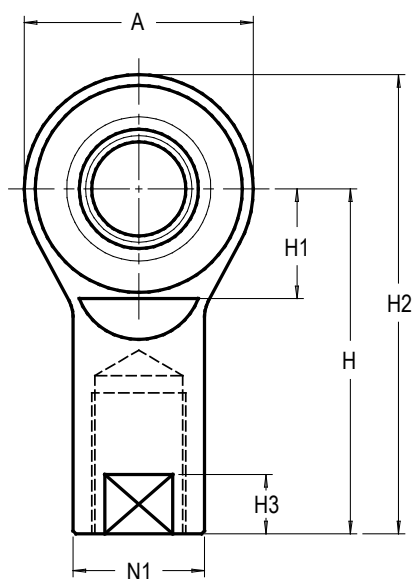

Ref. Item*	Dimension G	Capacités (N)		Ød	A	B	C	H	a (degré)	Ød1	G1	H1	H2	H3	N	N1	Poids (kg)
		Dynamiques	Statiques														
EMBOF-M6-BA	M6	3600	9000	6	21	6	4.3	30	13	10	11	10.5	40.5	8	9	11	0.017
EMBOF-M8-BA	M8	5850	14600	8	24	8	6	36	15	13	15	12	48	10	11	13	0.034
EMBOF-M10-BA	M10	8560	21600	10	29	9	7	43	12	16	15	14	57.5	11	14	16	0.060
EMBOF-M12-BA	M12	11400	28500	12	34	10	8	50	10	18	18	17.5	67	12	17	19	0.095
EMBOF-M16-BA	M16	22400	52000	17	46	14	11	67	10	25	24	23	90	15	22	25	0.23
EMBOF-M24x2-BA	M24x2	51000	102000	25	64	20	17	94	7	35.5	36	32	126	18	30	35	0.62
EMBOF-M30x2-BA	M30x2	65500	134000	30	73	22	19	110	6	40.7	45	35	146.5	19	36	42	0.97
EMBOF-M36x3-PTFE	M36x3	112000	143000	35	82	25	21	125	6	47	60	42	166	15	50	47	1.4
EMBOF-M45x3-PTFE	M45x3	220000	280000	50	112	35	30	160	6	66	68	60	216	20	65	62	3.55
EMBOF-M56x4-PTFE	M56x4	440000	630000	70	160	49	42	200	6	92	80	84	280	20	85	80	8.3
EMBOF-M64x4-PTFE	M64x4	570000	780000	80	180	55	47	230	6	105	85	100	320	25	100	95	13

\* Matière : BA - bronze auto-lubrifié; PTFE - polytétrafluoroéthylène

→ Autres capacités et dimensions disponibles sur demande

Dimensions en mm

Autre vue

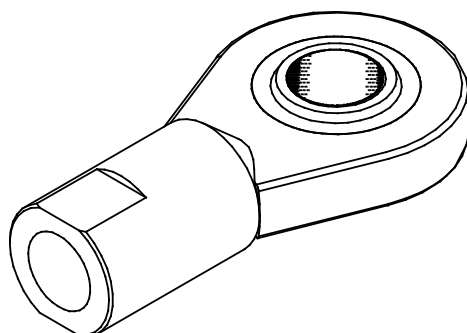

↳ PADIN > DIMENSIONS STANDARD

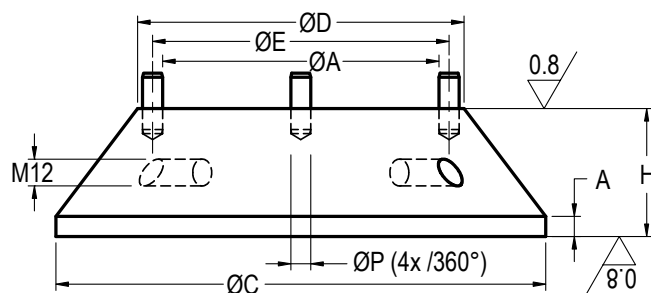

Ref. Item	Types	ØA	ØC	ØD	ØE	ØP	A	H	M12	Poids (kg)
PADIN-24	24	25	59	36	29	4	3	22	/	0.34
PADIN-30	30	31	64	40	35	4	3	22	/	0.4
PADIN-42	42	43	74	52	47	4	3	20	/	0.53
PADIN-45	45	46	79	56	50	4	3	21	/	0.64
PADIN-64	64	65	99	75	69	4	3	22	/	1.1
PADIN-64E	64E	65	129	75	69	4	4	25	/	1.8
PADIN-100A	100A	91	129	110	95	4	4	25	/	2.3
PADIN-100B	100B	100	129	110	104	4	4	25	/	2.3
PADIN-110E	110E	111	195	130	119	8	8	51	2x/360°	9.4
PADIN-125AA	125AA	120	158	144	128	8	6	25	/	3.7
PADIN-125AB	125AB	126	158	144	134	8	6	25	/	3.7
PADIN-125B	125B	126	195	150	134	8	8	45	2x/360°	9
PADIN-160	160	162	248	180	170	8	11	60	2x/360°	18.6
PADIN-200A	200A	202	308	235	214	12	12	67	2x/360°	32.9
PADIN-200B	200B	202	353	235	214	12	12	90	4x/360°	52.5
PADIN-210	210	207	248	225	215	8	6	30	2x/360°	11
PADIN-230	230	232	353	262	244	12	8	80	2x/360°	50
PADIN-250	250	252	438	280	264	12	10	80	4x/360°	69.75
PADIN-300	300	296	353	325	308	12	6	35	2x/360°	25.8
PADIN-330	330	333	438	370	349	16	8	60	4x/360°	62
PADIN-330A	330A	333	503	370	349	16	8	115	4x/360°	140
PADIN-365	365	367	503	400	379	12	8	80	4x/360°	105
PADIN-400A	400A	403	594	448	423	20	8	120	4x/360°	205
PADIN-445	445	448	594	485	464	16	8	85	4x/360°	156
PADIN-495	495	501	694	548	521	20	8	110	4x/360°	266
PADIN-540	540	546	795	613	576	30	8	130	4x M16 / 360°	405

→ Autres capacités et dimensions disponibles sur demande

Dimensions en mm

Autres vues

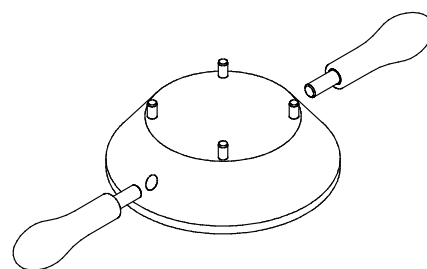
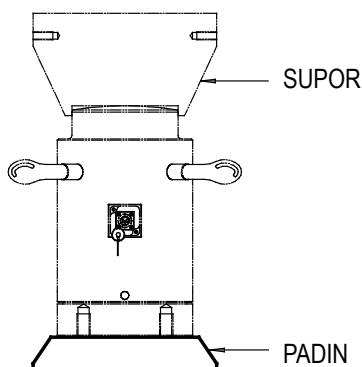
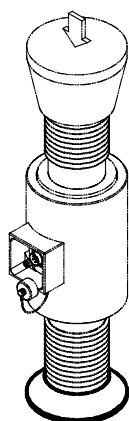

↳ SUPOR > DIMENSIONS STANDARD

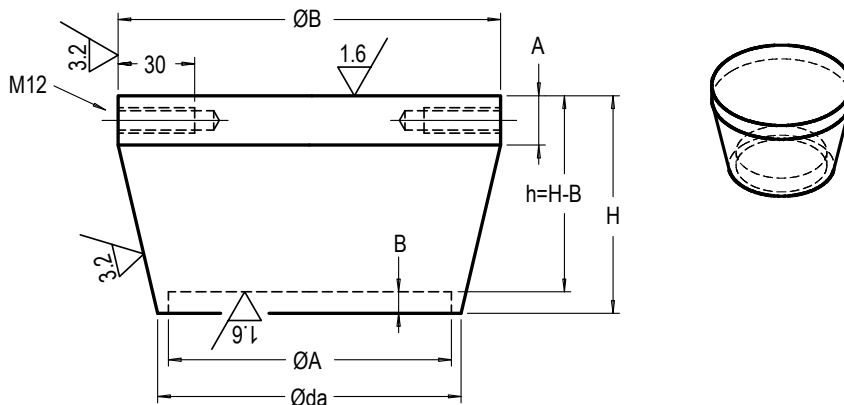

Ref. Item	Types	ØA	ØB	Øda	A	B	H	h	M12 L=30 (degré)	Poids (kg)
SUPOR-12	12	12	34	20	7	4	23	19	NO	0.12
SUPOR-20	20	20	49	30	8	5	31	26	NO	0.33
SUPOR-24	24	24	59	35	9	6	36	30	NO	0.55
SUPOR-30	30	30	64	40	9	6	41	35	NO	0.74
SUPOR-36	36	36	69	46	10	7	46	39	NO	0.98
SUPOR-45	45	45	79	56	11	12	53	41	NO	1.5
SUPOR-56	56	56	79	66	12	8	48	40	NO	1.5
SUPOR-64	64	64	99	75	12	17	64	47	NO	2.8
SUPOR-64E	64E	64	114	75	12	17	75	58	NO	4.14
SUPOR-69	69	69	79	75	12	12	52	40	NO	1.6
SUPOR-90	90	90	129	100	15	17	79	62	NO	6
SUPOR-90B	90B	90	164	100	15	17	109	92	NO	12.2
SUPOR-110	110	110	195	135	20	19	109	90	2x to 180	18.7
SUPOR-125A	125A	125	158	135	20	19	94	75	2x to 180	11.3
SUPOR-125B	125B	125	195	135	20	19	109	90	2x to 180	18.3
SUPOR-160	160	160	248	±170	30	20	146	126	2x to 180	40
SUPOR-200A	200A	200	308	±210	30	20	175	155	2x to 180	73
SUPOR-200B	200B	200	353	±210	30	20	200	180	4x to 90	103
SUPOR-230	230	230	353	±270	50	35	211.5	176.5	4x to 90	125
SUPOR-250A	250A	250	438	±290	40	30	250	220	6x to 60	209
SUPOR-250B	250B	250	503	±290	40	30	285	255	6x to 60	294
SUPOR-300A	300A	300	594	±340	50	40	337	297	6x to 60	481
SUPOR-330A	330A	330	503	±370	50	50	301.5	251.5	6x to 60	341
SUPOR-360A	360A	360	694	±401	100	50	397	347	6x M24 / 360	818
SUPOR-400A	400A	400	594	±440	50	55	352	297	6x to 60	555
SUPOR-430A	430A	430	795	±470	±100	50	448	398	6x M30 / 360	1209

→ Autres capacités et dimensions disponibles sur demande

Dimensions en mm

Autres vues

